



0832-CDP-1215



548p

## GST-IFP8

### Intelligent Fire Alarm

### Control Panel

GST-IFP8 Intelligent Fire Alarm Control Panel (FACP) is designed to comply with EN54-2 and EN54-4 standard (LPCB certificate No.: 548p) with qualities of simple installation, operation, and easy maintenance.

Modularized structure allowed the panel to be expanded to maximum 10 loops, 2420 devices can cover most medium projects.

- Sounder strobe output provides 1A/24V load, capable connecting conventional sounders.
- RS232 interface enables communication with PC.
- RS485 interface enables networking.
- RE485 interface for connecting repeaters.

### Features

- Max.999 zones, 140 of which has its own alarm and fault/disable LEDs and a label
- Maximum 8 Class A loops, each with up to 242 addressable devices (Optional 10 loops if not connected to network)
- 15X40 LCD screen, assisting the 17 LEDs to display important information
- Compatible with full series of GST addressable and digital products
- Non-Volatile memory ensures the data does not loss even if power supply is accidentally removed
- Automatically prompting operation steps after receiving alarm signal, according to pre-programmed equations

### Installation

GST-IFP8 FACP is wall/flush-mounted. Its appearance and the mounting hole are shown in Fig.1 and Fig.2.

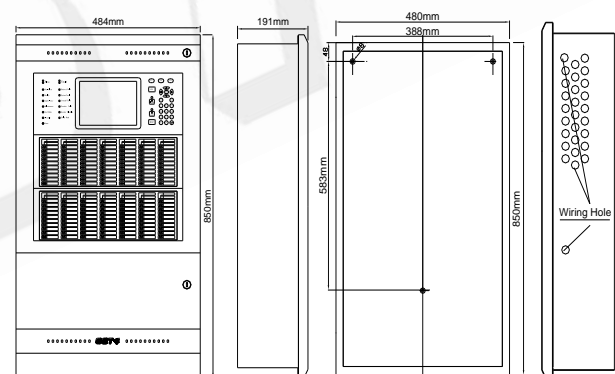

Fig.1

Fig.2

The wiring terminals and diagram are shown in the Fig.3 for reference.

This document is subject to change without notice. Please contact GST for more information or questions.

**Gulf Security Technology Co., Ltd.**

No. 80, Changjiang East Road, QETDZ, Qinhuangdao, Hebei, P. R. China 066004

www.gst.com.cn www.utcfireandsecurity.com service.gst@fs.utc.com

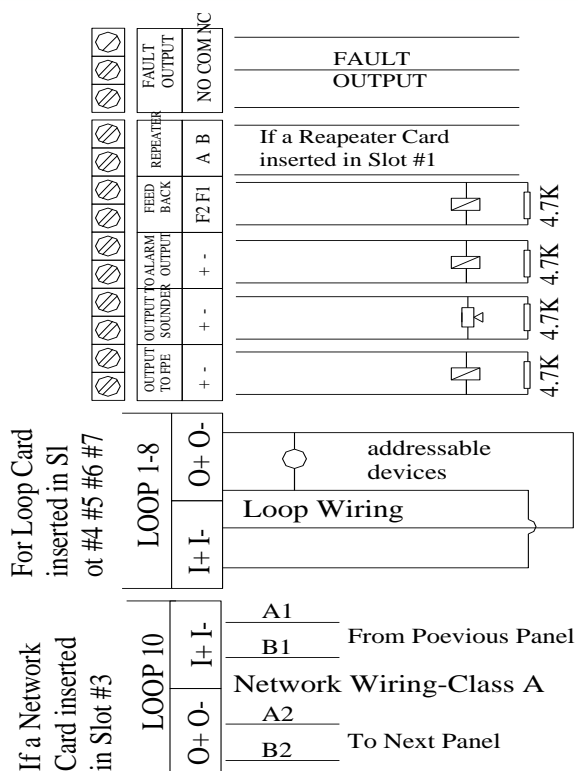

## Accessories and Tools

Model	Name	Remark
<b>Control Panel Expanders</b>		
P-9935	RS232 Communication Card	Order separately
P-9945A	RS485 network Card	Order separately
LCIFP8	Dual Loop Card	Order separately
P-9945RP	Repeater Card	Order separately
P-9902	Loop Splitter	Order separately
P-9903	Loop Relay Module	Order separately
<b>Annunciator</b>		
GST-GMC	Graphic Monitor Center	Order separately
GST852RP	LCD Repeater Panel	Order separately
GST-NRP01	Network Repeater Panel	Order separately
GST8903	Graphic Repeater Panel	Order separately
<b>Accessories</b>		
P-9910B	Hand Held Programmer	Order separately

Please contact with GST sales for compatible devices.

## Specification

Primary AC	220/230VAC, 50/60Hz
System Power	1A totally
Loop Quantity	2-8 Class A Loops
Zone Quantity	999 (140 with individual alarm/fault indicator and label)
Device per loop	242
Outputs/Inputs	Fixed Alarm Routing / Feed Back / F.P.E /Fault / Sounder
Display	15(lines) x 40(characters), LCD
Network	RS485 interface (Max. 32 panels)
PC Port	RS232 interface
Operating Environment	0°C~+40°C ≤95%, non condensing
Dimensions	484mm(W)x850mm(H)x191mm(D)

This document is subject to change without notice. Please contact GST for more information or questions.

**Gulf Security Technology Co., Ltd.**

No. 80, Changjiang East Road, QETDZ, Qinhuangdao, Hebei, P. R. China 066004

www.gst.com.cn www.utcfireandsecurity.com service.gst@fs.utc.com